

IP.1: PLAN VIEW

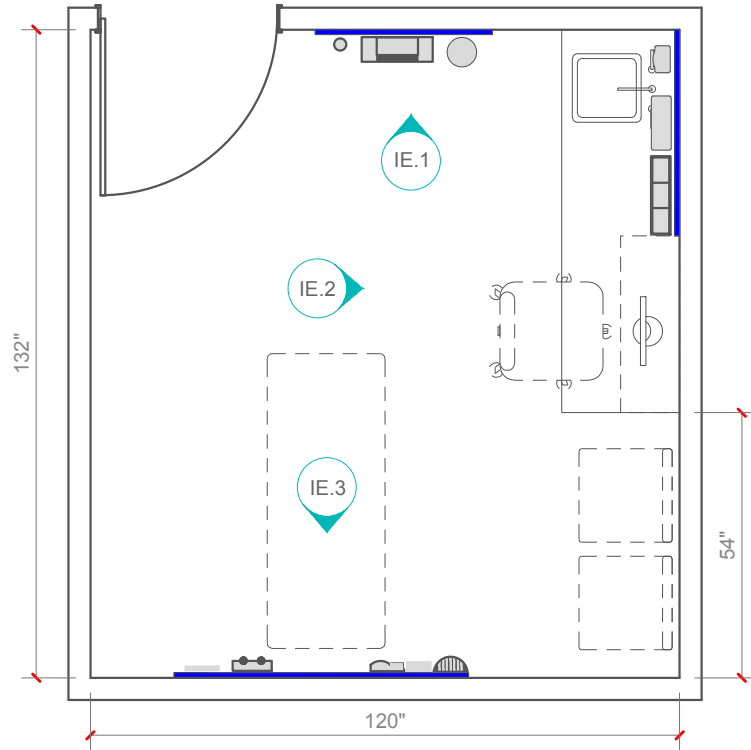

IE.1: PARTIAL ELEVATION

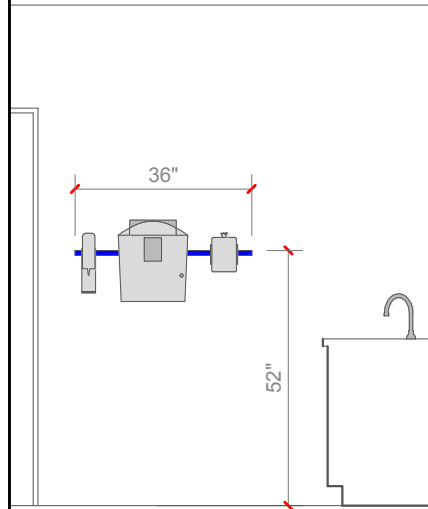

IE.2: PARTIAL ELEVATION

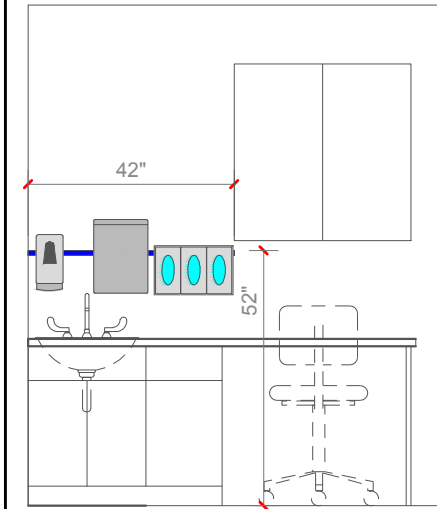

IE.3: ELEVATION

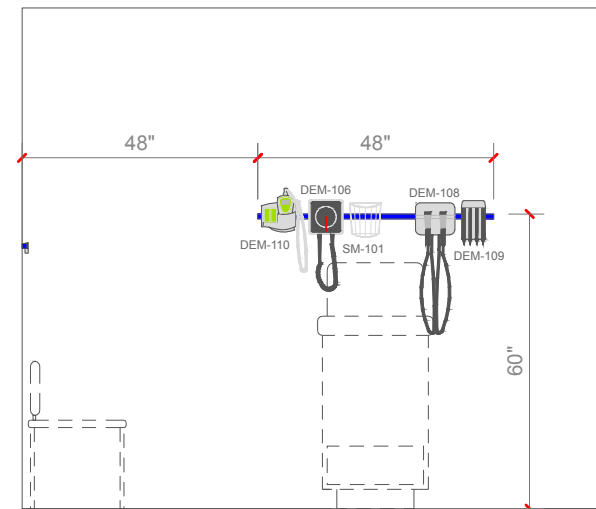

940 W. Oakland Avenue, A1  
Oakland, FL 34787  
(407) 614-8781 Office  
info@paladinmp.com

PACKAGE:  
**NOT FOR  
CONSTRUCTION**

APPROVAL DATE:

TYPICAL EXAM ROOM  
BASE CABINET AND  
OVERHEAD CASEWORK  
WITH SINK

SCALE: N.T.S.	REV 2:
DATE: 06-18-15	REV 3:
REV 1:	REV 4:

**EX.4**  
SHEET NO.

COPYRIGHT (C) 2013 BY PALADIN HEALTHCARE LLC. ALL RIGHTS RESERVED. THIS DOCUMENT IS THE PROPERTY OF PALADIN HEALTHCARE LLC. IT IS TO BE USED ONLY FOR THE SPECIFIC PROJECT IDENTIFIED OR REFERRED TO HEREIN AND IS NOT TO BE USED ON OTHER PROJECTS OR EXTENSIONS TO THIS PROJECT, IN WHOLE OR PART, EXCEPT BY EXPRESS WRITTEN AGREEMENT WITH AND COMPENSATION TO PALADIN HEALTHCARE LLC.